

This article was downloaded by:

On: 23 January 2011

Access details: *Access Details: Free Access*

Publisher *Taylor & Francis*

Informa Ltd Registered in England and Wales Registered Number: 1072954 Registered office: Mortimer House, 37-41 Mortimer Street, London W1T 3JH, UK



Journal of Coordination Chemistry

Publication details, including instructions for authors and subscription information:

<http://www.informaworld.com/smpp/title~content=t713455674>

STRUCTURAL STUDIES OF POLYETHER COORDINATION TO MERCURY(II) HALIDES: CROWN ETHER VERSUS POLYETHYLENE GLYCOL COMPLEXATION

Robin D. Rogers^a; Andrew H. Bond^a; Janice L. Wolff^a

^a Department of Chemistry, Northern Illinois University, DeKalb, IL, U.S.A.

To cite this Article Rogers, Robin D. , Bond, Andrew H. and Wolff, Janice L.(1993) 'STRUCTURAL STUDIES OF POLYETHER COORDINATION TO MERCURY(II) HALIDES: CROWN ETHER VERSUS POLYETHYLENE GLYCOL COMPLEXATION', *Journal of Coordination Chemistry*, 29: 4, 187 – 207

To link to this Article: DOI: 10.1080/00958979308037425

URL: <http://dx.doi.org/10.1080/00958979308037425>

PLEASE SCROLL DOWN FOR ARTICLE

Full terms and conditions of use: <http://www.informaworld.com/terms-and-conditions-of-access.pdf>

This article may be used for research, teaching and private study purposes. Any substantial or systematic reproduction, re-distribution, re-selling, loan or sub-licensing, systematic supply or distribution in any form to anyone is expressly forbidden.

The publisher does not give any warranty express or implied or make any representation that the contents will be complete or accurate or up to date. The accuracy of any instructions, formulae and drug doses should be independently verified with primary sources. The publisher shall not be liable for any loss, actions, claims, proceedings, demand or costs or damages whatsoever or howsoever caused arising directly or indirectly in connection with or arising out of the use of this material.

STRUCTURAL STUDIES OF POLYETHER COORDINATION TO MERCURY(II) HALIDES: CROWN ETHER VERSUS POLYETHYLENE GLYCOL COMPLEXATION

ROBIN D. ROGERS,* ANDREW H. BOND and JANICE L. WOLFF

Department of Chemistry, Northern Illinois University, DeKalb, IL 60115, U.S.A.

(Received 6 March 1992; in final form 3 August 1992)

The crystal structures of several crown ether and polyethylene glycol complexes of HgX_2 ($X = \text{Cl, Br, I}$) have been investigated. The crown ether complexes studied are $[\text{HgX}_2(18\text{-crown-6})]$ ($X = \text{Br, I}$) and $[\text{HgI}_2(\text{dibenzo-18-crown-6})]\cdot\text{CH}_3\text{CN}$. In each case Hg resides in the cavity of the ether resulting in hexagonal bipyramidal geometry with axial, terminal halides. The covalently bonded halides reside closer to Hg than the oxygen donor atoms. Five polyethylene glycol complexes have been structurally characterized: $[(\text{HgCl}_2)_3(\text{EO3})]$, $[\text{HgX}_2(\text{EO4})]$ ($X = \text{Br, I}$), $[\text{HgCl}_2(\text{EO5})]$, and $[\text{HgBr}_2(\text{EO5})\text{HgBr}_2]_2$ ($\text{EO3} = \text{triethylene glycol}$, $\text{EO4} = \text{tetraethylene glycol}$, $\text{EO5} = \text{pentaethylene glycol}$). The EO4 and EO5 glycols mimic crown ethers by forming an equatorial girdle around Hg although in each case one alcoholic terminal end does not coordinate to the metal ion. Each complex also has two covalent, nearly linear, axial halides coordinated to Hg. In $[(\text{HgCl}_2)_3(\text{EO3})]$, the glycol is linear and coordinates to three Hg atoms all on the same side of the glycol ligand. This structure is polymeric *via* chloride bridging.

KEY WORDS: 18-crown-6, dibenzo-18-crown-6, polyethylene glycol, triethylene glycol, tetraethylene glycol, pentaethylene glycol, mercury(II), chloride, bromide, iodide, X-ray structure.

INTRODUCTION

Mercury because of its environmental importance, has attracted the attention of scientists seeking to design synthetic ionophores capable of selectively complexing and transporting it.^{1–3} 18-Membered macrocycles with six donors (e.g., 18-crown-6) have been found to have an appropriate size for favourable interaction with Hg. This has been confirmed with X-ray structures of $[\text{HgX}_2(18\text{-crown-6})]$ ($X = \text{Cl}^4, \text{I}^5, \text{SCN}^6$) and $[\text{HgCl}_2(\text{dibenzo-18-crown-6})]$.⁷ Current research in this area seeks to replace oxygen donors with softer nitrogen and sulfur donors in 18-membered macrocycles in order to take advantage of the soft nature of Hg.^{8–12}

Several investigations of HgX_2 compounds complexed with linear polyethers have resulted in the isolation of different structural types.^{13–19} The majority of the structures have a linear X-Hg-X fragment coordinated to an equatorial girdle of oxygen donor atoms.^{14–16,18} The structures with five donor atoms coordinate with internal O-Hg-O angles of *ca* 60°, similar to those observed for 18-membered

* Author for correspondence.

macrocycles with six donors. IR, NQR, Raman, and ^{13}C NMR studies suggest that in solution even the short acyclic polyethers can form linear structures in which the ether coordinates to two or more metal ions.^{20–23}

We were drawn to the present study of Hg polyether complexes by the variety of structural types possible for HgX_2 polyethylene glycol (PEG) complexes. We have previously observed PEG coordination mimicing out-of-cavity crown ether coordination (in bismuth(III) halide complexes²⁴), mimicing in-cavity crown ether coordination (in bismuth(III) nitrate complexes²⁵ and in a few late lanthanide (III) chloride complexes^{26,27}), wrapping hard donor lanthanide(III) ions in a helical fashion,²⁸ and in one rare instance acting as a monodentate ligand.^{29,30} Adding to the expected structural diversity in Hg complexation were possibilities of polymeric halide bridging, differences in Hg-X covalent bonding as X varies from Cl to I, and for the PEG complexes, the possibility of significant intermolecular hydrogen bonding.

This report details our structural results for short chain (4 to 6 donor) PEG complexes of HgX_2 (X = Cl, Br, I). The complexes $[(\text{HgCl}_2)_3(\text{EO}3)]$, $[\text{HgX}_2(\text{EO}4)]$ (X = Br, I), $[\text{HgCl}_2(\text{EO}5)]$, and $[\text{HgBr}_2(\text{EO}5)\text{HgBr}_2]_2$ have been structurally characterized. For comparison we include the crystal structures of three HgX_2 crown ether complexes $[\text{HgX}_2(18\text{-crown-}6)]$ (X = Br, I) and $[\text{HgI}_2(\text{dibenzo-}18\text{-crown-}6)]\cdot\text{CH}_3\text{CN}$. In the discussion we compare these with the limited number of similar structures reported in the literature.

EXPERIMENTAL

Preparation of Complexes

CH_3CN and CH_3OH were distilled from CaH_2 and stored over 4Å molecular sieves prior to use. The metal salts, PEGs, and crown ethers were used as purchased without further purification. All melting points are uncorrected.

$[\text{HgCl}_2(18\text{-crown-}6)]$

To HgCl_2 (0.1364 g, 0.50 mmol) were added 3:1 $\text{CH}_3\text{CN}:\text{CH}_3\text{OH}$ (5 cm^3) and 18-crown-6 (0.1322 g, 0.50 mmol); the latter instantaneously produced a precipitate. The mixture was stirred at 60°C for 1 h, then centrifuged to remove the solid. The supernatant was decanted and stored at 5°C for 1.5 h during which time crystals had formed. The crystals were confirmed to be $[\text{HgCl}_2(18\text{-crown-}6)]$ by comparison of the unit cell parameters with those reported by Paige and Richardson.⁴ The precipitate was dried *in vacuo* prior to combustion analysis. Anal.: calcd. C, 26.90, H, 4.51%. Found for precipitate: C, 26.88; H, 4.85%.

$[\text{HgBr}_2(18\text{-crown-}6)]$

To HgBr_2 (0.1800 g, 0.50 mmol) were added 3:1 $\text{CH}_3\text{CN}:\text{CH}_3\text{OH}$ (5 cm^3) and 18-crown-6 (0.1329 g, 0.50 mmol), the latter immediately producing a white precipitate. The mixture was stirred at 60°C for 1 h, then centrifuged to remove the persistent white precipitate. The supernatant was decanted and stored at 5 and -10°C for 24 h. Slow evaporation produced crystals. The precipitate and crystals were dried *in vacuo* prior to combustion analysis. Melting range: $154\text{--}192^\circ\text{C}$. Anal.: calcd. C, 23.07; H, 3.87%. Found for precipitate: C, 23.26; H, 4.20%. Found for crystals: C, 27.81; H, 4.71%.

[HgI₂(18-crown-6)]

To HgI₂ (0.2270 g, 0.50 mmol) were added 3:1 CH₃CN:CH₃OH (5 cm³) and 18-crown-6 (0.1331 g, 0.50 mmol). The solution was stirred at 60°C for 1 h and a white precipitate formed. The solid was centrifuged and the supernatant decanted and stored at 5 and -10°C for 48 h. Slow concentration provided diffraction quality crystals. The precipitate was dried *in vacuo* prior to combustion analysis. Melting range: 170–180°C. Anal.: calcd. C, 20.05; H, 3.37%. Found for precipitate: C, 20.26; H, 3.51%.

[HgI₂(dibenzo-18-crown-6)]·CH₃CN

To HgI₂ (0.2270 g, 0.50 mmol) were added 3:1 CH₃CN:CH₃OH (5 cm³) and dibenzo-18-crown-6 (0.1836 g, 0.51 mmol). The reaction solution turned white with stirring at 60°C for 1 h. The precipitate was centrifuged and the supernatant decanted and stored at 5 and -10°C for 48 h. Slow evaporation provided diffraction quality crystals. Both the precipitate and the crystals were dried *in vacuo* prior to combustion analysis. Melting point: 188–191°C. Anal.: calcd. C, 30.87; H, 3.18%. Found for precipitate: C, 30.51; H, 3.27%. Found for crystals: C, 30.20; H, 3.00%.

[(HgCl₂)₃(EO3)]

To HgCl₂ (0.1362 g, 0.50 mmol) were added 3:1 CH₃CN:CH₃OH (5 cm³) and EO3 (67 × 10⁻⁶ cm³, 0.50 mmol). The solution was stirred at 60°C for 2.25 h and promptly placed into storage at 3°C for 48 h. Slow evaporation afforded crystalline material that decomposed in air. Crystals for the diffraction study were mounted in an Ar atmosphere saturated with the reaction solvent and were stable during the course of data collection. Melting range: 117–170°C. Anal.: calcd. C, 7.47; H, 1.46%. Found: C, 5.64; H, 1.33%.

[HgBr₂(EO4)]

To HgBr₂ (0.1802 g, 0.50 mmol) were added 3:1 CH₃CN:CH₃OH (5 cm³) and EO4 (86 × 10⁻⁶ cm³, 0.50 mmol). Stirring at 60°C for 2 h was followed by storage at 3°C for 168 h and -10°C for 48 h. Slow concentration afforded clear crystals. Melting point: 75°C. Anal.: calcd. C, 17.32; H, 3.27%. Found: C, 17.36; H, 3.43%.

[HgI₂(EO4)]

To HgI₂ (0.2773 g, 0.50 mmol) were added 3:1 CH₃CN:CH₃OH (5 cm³) and EO4 (86 × 10⁻⁶ cm³, 0.50 mmol). The reaction solution was stirred at 60°C for 2.25 h, and then centrifuged to remove undissolved HgI₂. The supernatant was stored at 3°C for 216 h (followed by slow evaporation). A microcrystalline product formed and this was dissolved in 2 cm³ of the solvent mixture, stirred at 60°C for 1.75 h, and slowly concentrated to provide diffraction quality crystals. Decomposition range: 49–62°C. Anal.: calcd. C, 14.81; H, 2.80%. Found: C, 16.33; H, 2.97%.

[HgCl₂(EO5)]

To HgCl₂ (0.1360 gm 0.50 mmol) were added 3:1 CH₃CN:CH₃OH (5 cm³) and EO5 (106 × 10⁻⁶ cm³, 0.50 mmol). The mixture was stirred at 60°C for 2.25 h, then stored

at 3 and -10°C for 48 and 120 h, respectively. Evaporation to dryness was followed by dissolution as above and stirring at 60°C for 1.5 h. Slow evaporation afforded hygroscopic crystals. Melting point: 75°C . Anal.: calcd. C, 23.56; H, 4.35%. Found: C, 24.19; H, 4.54%.

[HgBr₂(EO5)HgBr₂]₂

To HgBr₂ (0.1800 g, 0.50 mmol) were added 3:1 CH₃CN:CH₃OH (5 cm³) and EO5 (106 × 10⁻⁶ cm³, 0.50 mmol). The solution was stirred at 60°C for 2 h and stored at 3 and -10°C for 168 and 48 h, respectively. Slow evaporation produced crystalline material. Melting range: $75\text{--}87^{\circ}\text{C}$. Anal.: calcd. C, 12.52; H, 2.31%. Found: C, 14.02; H, 2.76%.

X-ray Data Collection, Structure Determination, and Refinement

A single crystal of each complex was mounted in a thin-walled glass capillary flushed with argon and transferred to the goniometer ($[(\text{HgCl}_2)_3(\text{EO3})]$ had to be mounted in an argon atmosphere saturated with the reaction solvent). Space groups were determined either from systematic absences ($P2_1/n$, $P2_1/c$) or by successful solution and refinement of the structures ($P\bar{1}$). Crystal data and data collection and refinement parameters are summarized in Table 1. Positional parameters are given in Tables 2 to 9.

The geometrically constrained hydrogen atoms (except for $[\text{HgCl}_2(\text{EO5})]$) were placed in calculated positions 0.95\AA from the bonded carbon atom and allowed to ride on that atom with B fixed at 5.5\AA^2 . The alcoholic hydrogen atoms were not included in the final refinements. Except as noted, non-hydrogen atoms were refined anisotropically. Details specific to each structure are given below.

[HgX₂(18-crown-6)] (X = Br, I)

After finding the preliminary unit cell for X = I, it initially appeared that this compound was C -centered monoclinic with $a = 11.238$, $b = 13.151$, $c = 8.608\text{\AA}$, $\beta = 130.7^{\circ}$. This cell was similar enough to that already reported for $[\text{HgI}_2(18\text{-crown-6})]$ ($a = 13.049(5)$, $b = 11.241(3)$, $c = 9.285(2)\text{\AA}$, $\beta = 134.89(3^{\circ})$ in $C2/m$)⁵ to cause concern. A thorough investigation, however, revealed the transformed cell to have triclinic equivalences. This situation was also reported for $[\text{HgCl}_2(18\text{-crown-6})]$; however, a higher symmetry cell ($R\bar{3}$) was found and finally utilized in that refinement⁴ (The $C\bar{1}$ cell initially investigated by Paige and Ruchardson⁴ for this X = Cl compound had dimensions $a = 10.444(2)$, $b = 11.458(1)$, $c = 7.745(1)\text{\AA}$, $\alpha = 90.04(1)$, $\beta = 82.21(2)$, $\gamma = 90.01(1)^{\circ}$). $[\text{CdI}_2(18\text{-crown-6})]$ was found to crystallize in yet another cell, $Pnma$, with $a = 16.563(3)$, $b = 27.996(5)$, $c = 8.382(2)\text{\AA}$.³¹

Neither the X = Br or I derivative crystallizes with the same unit cell, nor does it possess crystallographic symmetry as high as the molecule would permit. The difficulty in determining these structures seems to lie in the linear X-Hg-X fragment which dominates X-ray scattering. The symmetry permitted by the alignment in the unit cells of these linear units is higher than permitted by the entire complex. The weak contributions to the overall scattering by the C, H, and O atoms are often missed, resulting in indications of higher symmetry. It is still not clear, however, why these complexes do not crystallize in identical higher symmetry space groups.

Table 1 Crystal data and summary of data collection and structure refinement

Compound	[HgBr ₂ (18-crown-6)]	[HgI ₂ (18-crown-6)]	[HgI ₂ (di-benzo-18-crown-6)]·CH ₃ CN	[HgCl ₂ (EO3)]	[HgBr ₂ (EO4)]	[HgI ₂ (EO4)]	[HgCl ₂ (EO5)]	[HgBr ₂ (EO5)]
Colour/Shape	Colourless/parallelleptepid	Colourless/parallelleptepid	Colourless/parallelleptepid	Colourless/parallelleptepid	Colourless/parallelleptepid	Colourless/parallelleptepid	Colourless/parallelleptepid	Colourless/parallelleptepid
Formula weight	624.72	718.72	855.86	964.66	554.63	648.63	509.78	1918.2
Space group	<i>P</i> 2 ₁ / <i>c</i>	<i>P</i> 1	<i>P</i> 2 ₁ / <i>c</i>	<i>P</i> 1	<i>P</i> 2 ₁ / <i>n</i>	<i>P</i> 1	<i>P</i> 2 ₁ / <i>c</i>	<i>P</i> 1
Temp., °C	22	18	22	18	22	23	18	22
Cell Constants ^a								
<i>a</i> , Å	7.954(2)	8.608(3)	9.102(6)	7.883(2)	8.029(2)	8.235(6)	7.810(4)	8.055(2)
<i>b</i> , Å	14.349(9)	8.649(3)	10.751(6)	9.936(6)	8.068(2)	8.473(2)	14.652(2)	10.415(5)
<i>c</i> , Å	7.959(2)	8.649(1)	27.319(9)	11.816(4)	23.414(4)	12.090(6)	14.982(2)	14.021(3)
<i>α</i> , deg	93.91(2)	98.97(2)	99.00(5)	101.73(4)	98.81(2)	100.92(3)	95.07(3)	98.37(3)
<i>β</i> , deg	115.23(3)	115.23(3)	90.55(2)	90.55(2)	98.81(2)	101.38(7)	103.09(2)	103.09(2)
<i>γ</i> , deg	114.93(3)	114.93(3)	97.26(3)	97.26(3)	94.79(4)	94.79(4)	106.78(3)	106.78(3)
Cell volume Å ³	906.3	482.0	2640	898.3	1499	805.6	1708	1068
Formula units/unit cell	2	1	4	2	4	2	4	1
<i>D</i> _{calc} , g cm ⁻³	2.29	2.48	2.15	3.57	2.46	2.67	1.98	2.98
<i>μ</i> _{exp} , cm ⁻¹	134	114	83.4	270	161	136	95.1	226
Diffractometer/Scan	Enraf-Nonius CAD-4/ <i>ω</i> -2θ	Enraf-Nonius CAD-4/ <i>ω</i> -2θ	Enraf-Nonius CAD-4/ <i>ω</i> -2θ	Enraf-Nonius CAD-4/ <i>ω</i> -2θ	Enraf-Nonius CAD-4/ <i>ω</i> -2θ	Enraf-Nonius CAD-4/ <i>ω</i> -2θ	Enraf-Nonius CAD-4/ <i>ω</i> -2θ	Enraf-Nonius CAD-4/ <i>ω</i> -2θ
Range of rel. transm. factors, %	45/100	49/100	47/100	8.6/100	40/100	60/100	36/100	48/100
Radiation (Å), graphite mono-chromator	MoK α (λ = 0.71073)	MoK α (λ = 0.71073)	MoK α (λ = 0.71073)	MoK α (λ = 0.71073)	MoK α (λ = 0.71073)	MoK α (λ = 0.71073)	MoK α (λ = 0.71073)	MoK α (λ = 0.71073)
Max crystal dimensions, mm	0.10 × 0.15 × 0.20	0.08 × 0.10 × 0.10	0.10 × 0.15 × 0.25	0.20 × 0.25 × 0.50	0.20 × 0.25 × 0.30	0.15 × 0.30 × 0.35	0.20 × 0.25 × 0.50	0.15 × 0.20 × 0.25
Scan width	0.80 + 0.35tan θ	0.80 + 0.35tan θ	0.80 + 0.35tan θ	0.80 + 0.35tan θ	0.80 + 0.35tan θ	0.80 + 0.35tan θ	0.80 + 0.35tan θ	0.80 + 0.35tan θ
Standard reflections	600/080/004	400/020/004	400/080/006	200/060/009	600/040/010,14	300/050/006	300/060/004	400/060/007
Decay of standards	± 2%	± 2%	± 1.5%	-16.6% (corrected)	± 3%	± 1.5%	± 2%	± 3%
Reflections measured	1792	1700	5198	3103	3041	2810	3237	3763
2 θ range, deg	2 ≤ 2 θ ≤ 50	2 ≤ 2 θ ≤ 50	2 ≤ 2 θ ≤ 50	2 ≤ 2 θ ≤ 50	2 ≤ 2 θ ≤ 50	2 ≤ 2 θ ≤ 50	2 ≤ 2 θ ≤ 50	2 ≤ 2 θ ≤ 50
Range of <i>h</i> , <i>k</i> , <i>l</i>	+9, -17, ± 9	+10, ± 10, ± 10	+10, ± 12, ± 32	+9, ± 11, ± 14	+9, +9, ± 27	+9, ± 10, ± 14	+9, +17, -17	+9, ± 12, ± 16
Reflections observed	1079	1226	1162	2182	1320	1895	1316	1654
[<i>F</i> _o > 5 σ (<i>F</i> _o)] ^b								
Computer programs ^c	SHELX ³²	SHELX	SHELX	SHELX	SHELX	SHELX	SHELX	SHELX
Structure solution	SHELXS ³³	SHELXS	SHELXS	SHELXS	SHELXS	SHELXS	SHELXS	SHELXS
No. of parameters	97	97	177	142	145	145	191	198
varied								
Weights	[$\sigma(F_o)^2 + 0.00013F_o^2$] ⁻¹	[$\sigma(F_o)^2 + 0.0058F_o^2$] ⁻¹	[$\sigma(F_o)^2 + 0.0018F_o^2$] ⁻¹	[$\sigma(F_o)^2 + 0.002F_o^2$] ⁻¹	[$\sigma(F_o)^2 + 0.00038F_o^2$] ⁻¹	[$\sigma(F_o)^2 + 0.018F_o^2$] ⁻¹	[$\sigma(F_o)^2 + 0.00077F_o^2$] ⁻¹	[$\sigma(F_o)^2 + 0.0012F_o^2$] ⁻¹
GOF	0.41	0.21	0.74	5.94	0.65	0.15	0.96	0.64
$R = \sum F_o - F_c / \sum F_o $	0.034	0.034	0.051	0.070	0.038	0.042	0.050	0.049
$R_w = \sum w F_o - F_c / \sum w F_o $	0.035	0.050	0.063	0.103	0.041	0.064	0.058	0.058
Largest feature final diff. map	0.6e ⁻³ Å ⁻³	0.7e ⁻³ Å ⁻³	0.9e ⁻³ Å ⁻³	3.5e ⁻³ Å ⁻³ near Hg	1.0e ⁻³ Å ⁻³	0.7e ⁻³ Å ⁻³	1.4e ⁻³ Å ⁻³	1.3e ⁻³ Å ⁻³

^aLeast-squares refinement of ($\sin\theta/\lambda$)² values for 24 reflections $\theta > 17^\circ$. ^bCorrections: Lorentz-polarization and absorption (empirical, psi scan). ^cNeutral scattering factors and anomalous dispersion corrections from ref 34.

Table 2 Final fractional coordinates for [HgBr₂(18-crown-6)]

Atom	<i>x/a</i>	<i>y/b</i>	<i>z/c</i>	<i>B</i> (eqv) ^a
Hg	0.000	0.000	0.000	1.89
Br	-0.1409(1)	-0.01529(7)	0.2615(1)	2.99
O(1)	0.3142(8)	0.0480(5)	0.1702(8)	2.29
O(2)	0.0538(8)	0.1822(5)	0.1149(9)	2.52
O(3)	-0.2245(8)	0.1457(5)	-0.1186(8)	2.35
C(1)	0.305(1)	0.1292(7)	0.261(1)	2.84
C(2)	0.226(1)	0.2047(7)	0.148(1)	2.99
C(3)	-0.037(1)	0.2540(7)	0.026(1)	2.73
C(4)	-0.219(1)	0.2225(7)	-0.002(1)	2.54
C(5)	-0.391(1)	0.1108(7)	-0.159(1)	2.74
C(6)	-0.378(1)	0.0271(7)	-0.270(1)	2.47

$$^a B(\text{eqv}) = 4/3[a^2\beta_{11} + b^2\beta_{22} + c^2\beta_{33} + ab(\cos\gamma)\beta_{12} + ac(\cos\beta)\beta_{13} + bc(\cos\alpha)\beta_{23}].$$

Table 3 Final fractional coordinates for [HgI₂(18-crown-6)]

Atom	<i>x/a</i>	<i>y/b</i>	<i>z/c</i>	<i>B</i> (eqv)
Hg	1.000	0.000	1.000	2.78
I	0.7883(1)	0.0642(1)	0.7240(1)	4.20
O(1)	1.353(1)	0.306(1)	1.049(1)	3.67
O(2)	1.205(1)	0.365(1)	1.282(1)	3.77
O(3)	0.794(1)	0.076(1)	1.157(1)	4.02
C(1)	1.471(2)	0.451(2)	1.231(2)	3.52
C(2)	1.334(2)	0.503(2)	1.249(2)	4.49
C(3)	1.068(2)	0.397(2)	1.304(2)	4.16
C(4)	0.937(2)	0.240(2)	1.330(2)	4.66
C(5)	0.669(2)	-0.081(2)	1.171(2)	5.89
C(6)	0.527(2)	-0.243(2)	0.979(2)	4.18

[HgI₂(dibenzo-18-crown-6)]·CH₃CN

The presence of solvent molecules reduced the percentage of observed reflections (observed/measured = 22%). Carbon and nitrogen atoms were refined isotropically to keep the data to parameter ratio as high as possible. Methyl hydrogen atoms were included as a rigid group with rotational freedom at the bonded carbon atom (C-H = 0.95 Å, *B* = 5.5 Å²).

[(HgCl₂)₃(EO3)]

The combination of crystal decay and a very large absorption correction combined to reduce the data quality. Carbon atoms could not be anisotropically refined, and the *R* values are high.

[HgCl₂(EO5)]

Initial examination of crystals of this complex gave a unit cell with *c* one half of its final value and absences corresponding to *P*2₁/*m*. Further examination revealed several reflections present with *c* doubled (to its current value) and *l* odd. For the current data set, the reflections with *l* odd are, in general, weak.

Table 4 Final fractional coordinates for [HgI₂(dibenzo-18-crown-6)]·CH₃CN

Atom	<i>x/a</i>	<i>y/b</i>	<i>z/c</i>	<i>B</i> (eqv)	
Hg	1.3368(2)	0.3705(2)	0.34923(7)	2.52	
I(1)	1.0492(4)	0.3634(3)	0.3463(1)	3.56	
I(2)	1.6249(4)	0.3868(3)	0.3485(1)	3.69	
O(1)	1.290(3)	0.507(2)	0.260(1)	3.19	
O(2)	1.313(3)	0.619(2)	0.3565(9)	3.21	
O(3)	1.353(3)	0.470(3)	0.444(1)	4.69	
O(4)	1.407(3)	0.235(2)	0.4423(9)	3.17	
O(5)	1.367(3)	0.108(2)	0.3470(9)	2.79	
O(6)	1.306(4)	0.261(3)	0.254(1)	4.25	
C(1)	1.266(5)	0.637(4)	0.269(1)	6(1)	^a
C(2)	1.353(5)	0.687(4)	0.316(2)	6(1)	^a
C(3)	1.393(4)	0.657(4)	0.406(1)	4.5(9)	^a
C(4)	1.334(5)	0.598(4)	0.444(2)	6(1)	^a
C(5)	1.304(5)	0.399(4)	0.482(2)	4.8(9)	^a
C(6)	1.325(5)	0.277(4)	0.480(2)	4.7(9)	^a
C(7)	1.405(4)	0.099(3)	0.432(1)	3.5(8)	^a
C(8)	1.480(4)	0.068(4)	0.387(1)	4.2(9)	^a
C(9)	1.415(5)	0.090(4)	0.301(1)	5(1)	^a
C(10)	1.287(4)	0.132(4)	0.256(1)	4.8(9)	^a
C(11)	1.190(5)	0.321(4)	0.217(1)	3.4(8)	^a
C(12)	1.188(6)	0.453(4)	0.225(2)	5(1)	^a
C(13)	1.091(6)	0.516(5)	0.190(2)	6(1)	^a
C(14)	0.985(6)	0.458(5)	0.157(2)	7(1)	^a
C(15)	1.002(5)	0.330(4)	0.155(2)	4.0(9)	^a
C(16)	1.108(5)	0.257(5)	0.186(2)	6(1)	^a
C(17)	1.285(5)	0.196(5)	0.513(2)	7(1)	^a
C(18)	1.214(5)	0.241(4)	0.551(2)	6(1)	^a
C(19)	1.169(5)	0.369(5)	0.549(2)	7(1)	^a
C(20)	1.231(5)	0.441(5)	0.517(2)	6(1)	^a
N	0.782(5)	0.132(5)	0.522(2)	8(1)	^a
C(21)	0.840(6)	0.141(5)	0.488(2)	7(1)	^a
C(22)	0.918(6)	0.179(6)	0.448(2)	9(2)	^a

^aIsotropic refinement.

The mercury, two chlorine, and most of the oxygen atoms were readily located and refined. The two terminal oxygen atoms exhibited very high thermal motion and it became apparent that these positions were disordered. Two orientations of each were located and refined in alternate least-squares cycles. Refinement of the occupancy factors revealed a major form (O(1), O(6) at 60%) and a minor form (O(1)', O(6)' at 40%). The origin of the disorder was obvious. Only five of the six oxygen atoms are coordinated to Hg. In the major conformation O(1) is coordinated and O(6) is not. This situation is reversed in the minor conformation in which O(6)' is coordinated and O(1)' is not. With two orientations of the terminal alcohols it was expected that the ethylene linkages leading to these atoms would also be disordered. While that is undoubtedly true, due to the proximity of the disordered positions we could not resolve the disorder. These atoms and the disordered oxygen atoms all exhibit large thermal ellipsoids.

Table 5 Final fractional coordinates for [(HgCl₂)₃(EO₃)]

Atom	<i>x/a</i>	<i>y/b</i>	<i>z/c</i>	<i>B</i> (eqv)
Hg(1)	0.1570(1)	0.8136(1)	0.89267(8)	2.23
Hg(2)	0.0893(1)	0.4892(1)	0.65611(8)	2.10
Hg(3)	0.0480(2)	0.1560(1)	0.77660(9)	2.61
Cl(1)	0.283(1)	0.7892(9)	1.0619(6)	2.97
Cl(2)	0.015(1)	0.8266(9)	0.7250(6)	2.97
Cl(3)	-0.037(1)	0.4968(9)	0.8314(6)	2.88
Cl(4)	0.2298(9)	0.4856(9)	0.4853(5)	2.70
Cl(5)	0.173(1)	0.1527(9)	0.9530(5)	2.98
Cl(6)	-0.103(1)	0.1677(9)	0.6112(6)	3.31
O(1)	0.452(4)	0.943(3)	0.838(3)	4.90
O(2)	0.391(3)	0.647(2)	0.761(1)	2.40
O(3)	0.335(3)	0.346(2)	0.743(1)	2.69
O(4)	0.297(3)	0.064(3)	0.644(2)	3.85
C(1)	0.573(4)	0.872(4)	0.762(3)	4.5(6) ^a
C(2)	0.472(4)	0.743(3)	0.693(2)	3.4(5) ^a
C(3)	0.511(4)	0.587(4)	0.822(3)	4.2(6) ^a
C(4)	0.413(4)	0.448(4)	0.839(2)	3.8(6) ^a
C(5)	0.464(5)	0.287(4)	0.676(3)	5.0(7) ^a
C(6)	0.380(4)	0.166(3)	0.589(2)	3.5(5) ^a

^aIsotropic refinement.**Table 6** Final fractional coordinates for [HgBr₂(EO₄)]

Atom	<i>x/a</i>	<i>y/b</i>	<i>z/c</i>	<i>B</i> (eqv)
Hg	0.08574(7)	0.5055(1)	0.39512(2)	2.54
Br(1)	-0.0569(2)	0.3288(2)	0.31899(8)	3.69
Br(2)	0.2219(3)	0.6280(2)	0.48490(8)	3.89
O(1)	-0.176(1)	0.723(1)	0.3777(5)	3.37
O(2)	0.121(1)	0.776(1)	0.3310(4)	2.98
O(3)	0.363(1)	0.517(1)	0.3386(4)	3.04
O(4)	0.354(1)	0.254(1)	0.4177(5)	3.04
O(5)	0.324(2)	0.196(2)	0.5308(5)	4.44
C(1)	-0.145(2)	0.870(2)	0.3474(8)	3.72
C(2)	-0.039(2)	0.839(2)	0.3023(7)	3.56
C(3)	0.238(2)	0.758(2)	0.2920(7)	3.72
C(4)	0.396(2)	0.682(2)	0.3244(7)	3.50
C(5)	0.509(2)	0.433(2)	0.3681(8)	3.92
C(6)	0.467(2)	0.261(2)	0.3772(7)	3.33
C(7)	0.310(2)	0.090(2)	0.4345(8)	4.33
C(8)	0.221(2)	0.112(2)	0.4865(8)	4.02

[HgBr₂(EO₅)HgBr₂]₂

Two conformations of the C(5)–C(6) ethylene unit were resolved and refined in alternate least-squares cycles. The major conformation (C(5)–C(6)) refined to 60% occupancy, while C(5)′–C(6)′ refined to 40% occupancy. These atoms were treated isotropically throughout the final stages of refinement.

Table 7 Final fractional coordinates for [HgI₂(EO₄)]

Atom	<i>x/a</i>	<i>y/b</i>	<i>z/c</i>	<i>B</i> (eqv)
Hg	0.17950(7)	0.01570(6)	0.20319(5)	3.01
I(1)	0.1369(1)	0.2349(1)	0.37484(9)	3.77
I(2)	0.2105(1)	-0.1466(1)	0.00474(8)	3.72
O(1)	-0.083(1)	-0.194(1)	0.225(1)	4.48
O(2)	0.247(1)	-0.240(1)	0.3102(8)	3.04
O(3)	0.510(1)	0.008(1)	0.3222(8)	3.02
O(4)	0.470(1)	0.252(1)	0.1848(8)	3.05
O(5)	0.343(2)	0.296(2)	-0.0359(9)	4.72
C(1)	-0.046(2)	-0.330(2)	0.271(2)	4.50
C(2)	0.108(2)	-0.283(2)	0.358(1)	3.68
C(3)	0.401(2)	-0.217(2)	0.390(1)	2.85
C(4)	0.533(2)	-0.147(2)	0.335(1)	3.19
C(5)	0.638(2)	0.080(2)	0.279(1)	3.28
C(6)	0.606(2)	0.250(2)	0.273(1)	4.23
C(7)	0.434(2)	0.405(2)	0.163(1)	3.90
C(8)	0.298(2)	0.383(2)	0.059(2)	4.83

Table 8 Final fractional coordinates for [HgCl₂(EO₅)]

Atom	<i>x/a</i>	<i>y/b</i>	<i>z/c</i>	<i>B</i> (eqv)
Hg	0.55811(9)	-0.75585(5)	0.42547(5)	3.83
Cl(1)	0.7237(7)	-0.8199(4)	0.5425(4)	5.40
Cl(2)	0.4075(8)	-0.6706(4)	0.3172(4)	5.79
O(1)	0.862(8)	-0.621(3)	0.419(5)	14.62
O(1) ^a	1.009(8)	-0.549(5)	0.371(6)	14.33
O(2)	0.834(2)	-0.777(1)	0.317(1)	5.42
O(3)	0.563(2)	-0.9031(8)	0.3127(8)	4.09
O(4)	0.320(2)	-0.8902(8)	0.4454(9)	4.24
O(5)	0.276(2)	-0.7248(9)	0.5352(9)	4.93
O(6)	0.252(7)	-0.532(2)	0.510(3)	12.51
O(6)'	0.537(9)	-0.600(4)	0.556(4)	9.26
C(1)	0.946(5)	-0.629(2)	0.366(3)	10.19
C(2)	0.912(4)	-0.699(2)	0.285(2)	8.07
C(3)	0.807(3)	-0.851(2)	0.251(2)	7.08
C(4)	0.726(3)	-0.930(2)	0.295(2)	6.63
C(5)	0.465(3)	-0.980(1)	0.348(2)	6.15
C(6)	0.291(3)	-0.948(1)	0.366(1)	4.70
C(7)	0.163(2)	-0.867(1)	0.480(1)	4.11
C(8)	0.206(3)	-0.809(1)	0.565(2)	5.08
C(9)	0.313(4)	-0.666(2)	0.609(1)	6.14
C(10)	0.367(6)	-0.579(2)	0.578(3)	9.48

^aO(1), O(1)', O(6), and O(6)' are disordered with occupancy factors of 60% for the unprimed positions and 40% for the primed positions.

RESULTS

[HgX₂(18-crown-6)] (X = Br, I)

An ORTEP illustration of the X = Br complex is given in Figure 1. Both the Br and I analogues have essentially the same structure as the previously reported chloride⁴

Table 9 Final fractional coordinates for $[\text{HgBr}_2(\text{EO5})\text{HgBr}_2]_2$

Atom	<i>x/a</i>	<i>y/b</i>	<i>z/c</i>	<i>B</i> (eqv)
Hg(1)	0.1862(2)	0.3260(1)	0.72780(8)	2.29
Hg(2)	0.0062(2)	-0.0115(1)	0.85024(9)	2.89
Br(1)	0.0467(4)	0.2805(3)	0.8638(2)	3.22
Br(2)	0.2884(4)	0.3323(4)	0.5773(2)	3.51
Br(3)	0.2378(4)	-0.0136(3)	0.9967(2)	3.43
Br(4)	-0.2465(4)	-0.1217(3)	0.6997(2)	3.62
O(1)	0.247(2)	0.070(2)	0.747(1)	2.62
O(2)	0.526(3)	0.335(2)	0.820(1)	2.98
O(3)	0.421(3)	0.569(2)	0.842(2)	3.88
O(4)	0.066(3)	0.550(2)	0.731(2)	5.03
O(5)	-0.145(3)	0.308(2)	0.586(1)	3.75
O(6)	-0.134(3)	0.112(2)	0.426(2)	4.35
C(1)	0.432(4)	0.090(3)	0.780(2)	3.69
C(2)	0.536(4)	0.219(3)	0.864(2)	3.92
C(3)	0.631(4)	0.461(3)	0.890(2)	3.08
C(4)	0.596(5)	0.579(3)	0.847(3)	5.80
C(5)	0.376(6)	0.678(5)	0.806(3)	3.5(9) ^a
C(6)	0.180(8)	0.663(6)	0.792(4)	5(1) ^a
C(5) ^b	0.35(1)	0.672(8)	0.860(6)	5(2) ^a
C(6) ^c	0.26(1)	0.680(8)	0.748(6)	5(2) ^a
C(7)	-0.050(5)	0.551(3)	0.647(2)	5.12
C(8)	-0.206(5)	0.417(4)	0.609(3)	4.86
C(9)	-0.281(4)	0.180(3)	0.538(3)	4.46
C(10)	-0.209(5)	0.076(3)	0.502(3)	4.19

^aIsotropic refinement. ^bThe ethylene unit C(5)-C(6) is disordered into two orientations with 60% occupancy (C(5)-C(6)) and 40% occupancy (C(5)^b-C(6)^c).

and iodide⁵ complexes; however, none of the four structures appears to be crystallographically isostructural. Each complex can support $\bar{3}$ symmetry, but only $[\text{HgCl}_2(18\text{-crown-6})]_4$ possesses such crystallographic symmetry and crystallizes in the space group $R\bar{3}$. The previously reported iodide complex crystallized in $C2/m$ with the Hg atom residing on a $2/m$ site.⁵ The two complexes reported here are the lowest symmetry yet determined, each residing on a centre of inversion in $P2_1/c$ ($X = \text{Br}$) or $P\bar{1}$ ($X = \text{I}$).

The low symmetry caused us concern in our solution of these structures and indeed both cells appear to indicate higher symmetry. However, every such cell examined was rejected either on the basis of lack of consistent equivalent reflections or the presence of supposedly systematically absent reflections. It is possible, given the nature of the bromide and iodide ions that very long and weak intermolecular interactions result in packing arrangements that do not allow the higher symmetry. The resulting structures do provide valuable bonding information and do not appear to suffer the effects of high correlations between parameters.

Each linear X-Hg-X fragment sits in the centre of a D_{3d} 18-crown-6 molecule. The hexagonal arrays of oxygen atoms around Hg are planar to within 0.24 Å with oxygen atom deviations alternating direction. The Hg-X distances (Table 10) in the four 18-crown-6 structures follow the trend associated with increasing halide size and range from Hg-Cl = 2.314(1) Å to Hg-I = 2.6237(7) Å. The average Hg-O distances appear to increase in the order Cl < Br < I with an 11σ difference in Hg-O separations

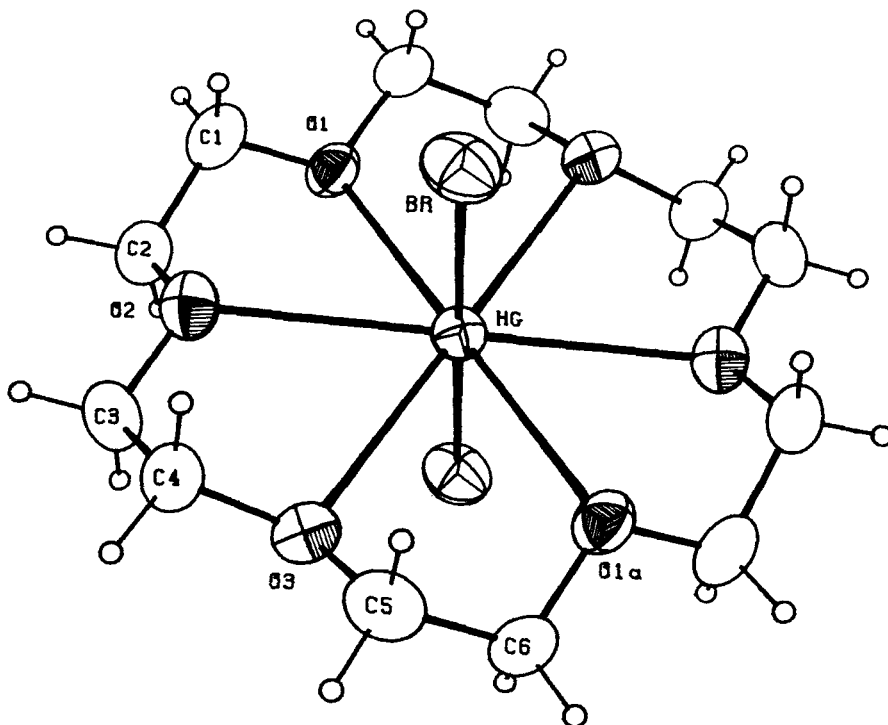

Figure 1 $[\text{HgBr}_2(18\text{-crown-6})]$ represented by 50% probability ellipsoids for thermal motion. The hydrogen atoms have been arbitrarily reduced. The Hg atom resides on a crystallographic centre of inversion. The symmetry code 'a' refers to $\bar{x}, \bar{y}, \bar{z}$.

in the chloride complex ($2.825(4)\text{\AA}$) versus our determination of the iodide analogue ($2.869(4)\text{\AA}$). Despite the different space groups and symmetries, the bonding parameters for both $\text{X}=\text{I}$ determinations are essentially identical.

[HgI₂(dibenzo-18-crown-6)]·CH₃CN

Figure 2 illustrates this complex. The Hg geometry is 6-coordinate, hexagonal bipyramidal with the two iodides in axial positions. The hexagonal plane of oxygen atoms is planar to within 0.12\AA and Hg resides 0.02\AA out of this mean plane. The Hg-I distances (Table 10) differ by 5σ with the longer I(2) coordinated outside the fold of the benzo substituents (the two benzene ring planes intersect at an angle of 102°). The Hg-I average separation ($2.62(1)\text{\AA}$) is identical to that observed for $[\text{HgI}_2(18\text{-crown-6})]$.

The Hg position appears to be slightly off centre, closer to O(1)-O(3) than O(4)-O(6), resulting in a range of 0.22\AA (7.3σ) in Hg-O separations. The Hg-O average distance ($2.81(7)\text{\AA}$) is essentially identical to that found for the structurally similar complex $[\text{HgCl}_2(\text{dibenzo-18-crown-6})]$.⁷

The solvent molecules may interact weakly with the iodine atoms *via* the C-H acidic protons. Closest solvent contacts are C(methyl)···I = $3.76(6)$ and $4.15(6)\text{\AA}$.

Table 10 Comparison of binding parameters in HgX₂ polyether complexes

Compound	CN	Geometry ^a	Hg-X (covalent Å)	X-Hg-X (covalent deg)	No. X donors	Hg-X (donor interactions- range, Å)	No. O donors	Hg-O (alcoholic, Å)	Hg-O(etheric)		O-Hg-O (cis angles, deg)	Ref		
									Range(Å)	Δ				
[HgX ₂ (18-crown-6)]														
X = Cl	8	hbp	2.314(1)	180	0		6				2.825(4)	60.6(1)	4	
X = Br	8	hbp	2.440(1)	180	0		6				2.84(3)	60.5(2)	This study	
X = I	8	hbp	2.622(1)	180	0		6				2.86(1)	60.7(1)	5	
X = I	8	hbp	2.6237(7)	180	0		6				2.863(7)-2.872(8)	60.7(1)	This study	
X = SCN	8	hbp	2.356(9)(S)	180	0		6				2.78(2)-2.84(2)	60.7(7)	6	
[HgCl ₂ (dibenzo-18-crown-6)]	8	hbp	2.36(4)	176.9(7)	0		6				2.79	60(4)	This study	
[HgI ₂ (dibenzo-18-crown-6)]- ·CH ₃ CN	8	hbp	2.62(1)	177.0(2)	0		6				2.81(7)		7	
[HgCl ₂] ₃ (EO3)]	7	pbp	2.303(5)	176(1)	3	3.070(7)- 3.468(9)(br) ^b	2	2.66(3)			2.84(3)(br)	61.8(8)	This study	
[HgX ₂](EO4)]														
X = Br	7	pbp	2.427(1)	167.02(7)	1	4.157(2)(br)	4	2.72(1)			2.69(1)-2.95(1)	0.26	2.8(1)	62(2)
X = I	7	pbp	2.602(2)	166.06(4)	1	4.041(1)(br)	4	2.76(1)			2.770(9)-3.060(9)	0.29	2.9(1)	60(1)
[HgCl ₂ (EO5)]	7	pbp	2.287(1)	171.2(2)	0		5	3.06(4)			2.74(1)-2.90(1)	0.16	2.80(7)	59(3)
[HgBr ₂ (EO5)HgBr ₂] ₂														
Hg(1)	7	pbp	2.45(1)	170.2(1)	0		5	2.882(br)			2.69(2)-2.88(2)	0.19	2.76(7)	62(1)
Hg(2)	5	tbp	2.441(9)	153.4(1)	2	2.937(4)- 3.253(4)(br)	1	2.702(br)						This study
[HgCl ₂ (EO4R ₂)] ^c														
R = Me	7	pbp	2.30(1)	174.2	0		5				2.78-2.96	0.18	2.84(7)	61(1)
R = Et ^d	7	pbp	2.35	180	0		5							15
[HgBr ₂ (EO4R ₂)]														
R = CH ₂ -C ₆ H ₄ -Br	7	pbp	2.40(1)	174.4(1)	0		5				2.72(2)-3.06(1)	0.34	2.9(1)	61.2(8)
[(HgCl ₂) ₂ (EO6R ₂)]														
R = Et	7	pbp	2.31(1)	175.9	1	3.38	4				2.66-2.91	0.25	2.8(1)	62.6(6)

^aGeometries include hbp = hexagonal bipyramid; pbp = pentagonal bipyramid; tbp = trigonal bipyramid. Most geometries of the acyclic polyether complexes are moderately to severely distorted. ^bBridging atoms are designated (br). ^cEO # R₂ represents a glyme-like structure with terminal R groups rather than H atoms as found in PEGs. ^dThis structure is severely disordered.

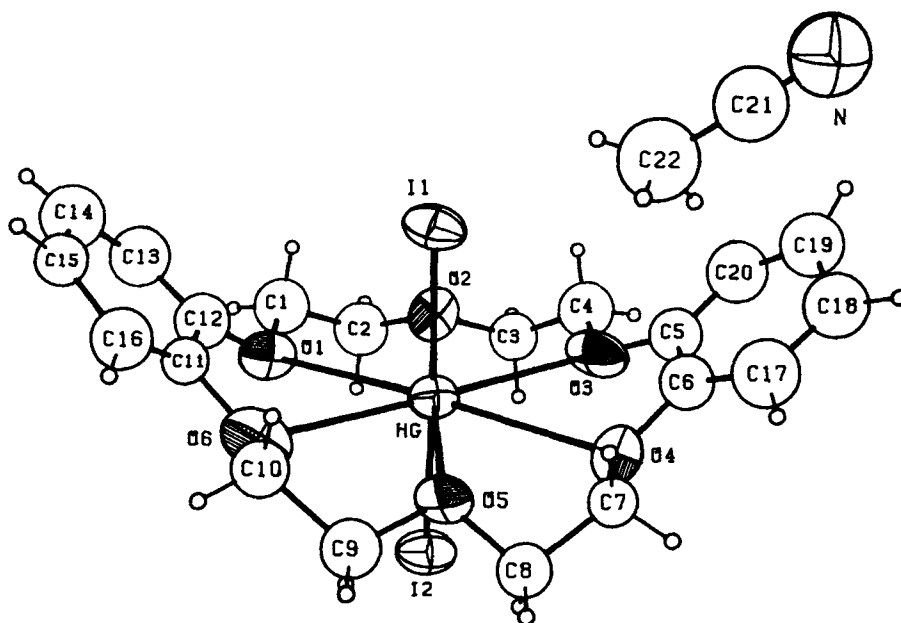

Figure 2 $[\text{HgI}_2(\text{dibenzo-18-crown-6})]\cdot\text{CH}_3\text{CN}$.

$[(\text{HgCl}_2)_3(\text{EO}_3)]$

This complex crystallizes with a linear polyether coordinated to three different linear HgCl_2 fragments each of which participates in secondary donor interactions with three additional chlorides. The atoms in the asymmetric unit are labelled in Figure 3. The overall coordination results in polymeric chains along unit cell direction b with the chains connected into sheets at every other Hg position (Hg(2)) with two bridging chlorides (Cl(3), Cl(4)). The polymeric nature of the bonding can be seen in Figure 4. The EO3 ligand is linear along b ; the chains are connected into sheets along c . Further polymeric interactions are generated by the hydrogen bonding between the alcoholic ends of the EO3 ligand and the chlorides.

Each mercury is pentagonal bipyramidal with two axial covalently bonded chlorides and five equatorial donor groups (two oxygen atoms and three chlorine atoms). The equatorial atoms have an average deviation from the planes of 0.33\AA . Hg(2) (which is involved in the crosslinking of the chains) deviates 0.17\AA from its pentagonal coordination plane versus 0.06 and 0.01\AA for Hg(1) and Hg(3), respectively. The equatorial atoms around Hg(2) are also the most distorted with a maximum deviation of 0.52\AA . The pentagonal planes for Hg(1) and Hg(3) are nearly coplanar ($\delta = 8^\circ$) while the average dihedral angle between the similar planes in Hg(1)/Hg(2) and Hg(2)/Hg(3) average 57° .

The Hg-Cl covalent interactions average $2.303(5)\text{\AA}$ and fall within a narrow range (0.015\AA) despite the differing numbers of secondary interactions of each chloride. Hg-Cl secondary donor interactions range from $3.070(7)$ to $3.468(9)\text{\AA}$. The longest corresponds to the triply bridging Cl(3).

Two alcoholic oxygen atoms are both terminally coordinated to one Hg each at an

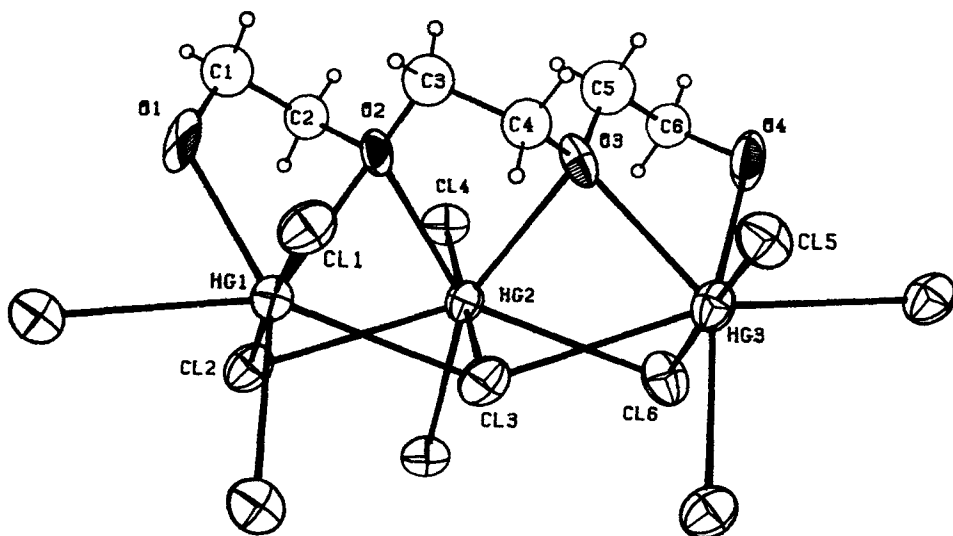

Figure 3 A portion of the polymeric chain comprising $[(\text{HgCl}_2)_3(\text{EO}_3)]$.

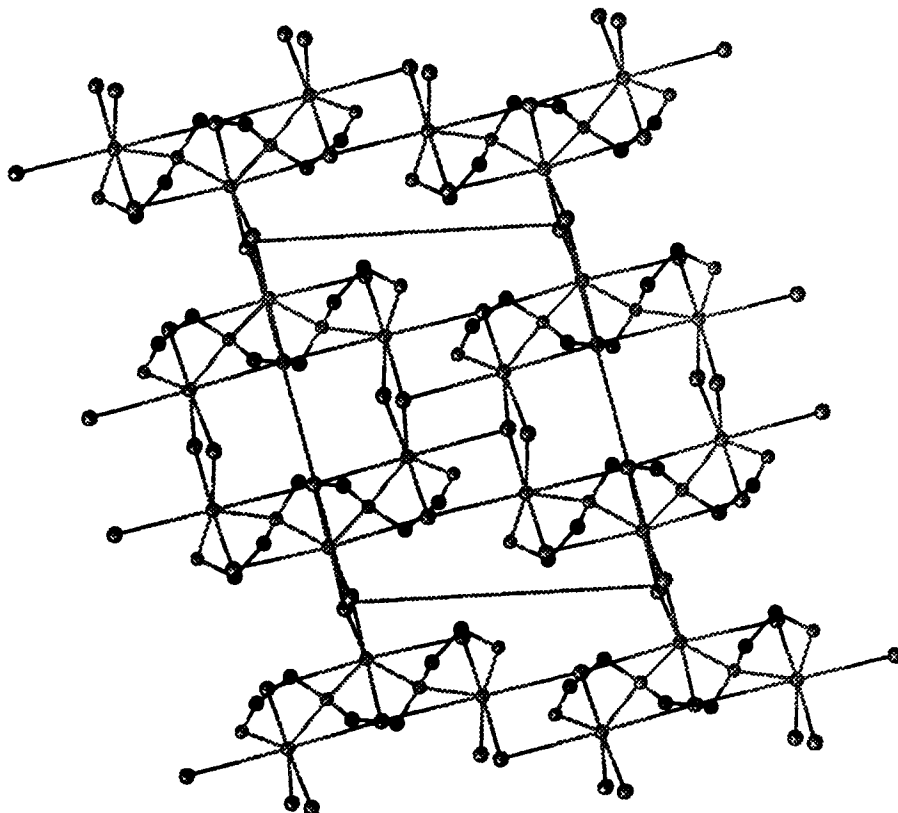

Figure 4 SYBYL (Tripos Assoc., St. Louis, MO, U.S.A.) representation of the *bc* plane in $[(\text{HgCl}_2)_3(\text{EO}_3)]$. The more darkly shaded atoms are carbon atoms.

identical Hg-O separation of 2.66(3)Å. Etheric oxygen atoms each bridge two Hg atoms with an average Hg-O distance of 2.84(3)Å.

[HgX₂(EO4)] (X = Br, I)

The X=Br and X=I analogues are structurally identical although not crystallographically isostructural. An ORTEP illustration of the bromide complex is presented in Figure 5. Differences may be related to the possibility of intermolecular hydrogen bonding between O(5) and I(2) in a molecule other than the hydrogen bonded dimer. There is a slightly better fit for such a hydrogen bonding scheme as determined by the contact geometries than is observed for the bromide analogue.

Several structural features observed for these complexes are found for all subsequent PEG complexes reported here. First, the PEG ligands wrap in a crown ether-like fashion around the equatorial plane of a linear X-Hg-X moiety; however, instead of completely encircling Hg, one end of the PEG chain does not coordinate the metal ion. This creates an open side toward which the X-Hg-X angle is bent producing significant (10–14°) deviations from linearity for this group. In addition, the Hg-O separations closest to the open side exhibit the longest such distances.

All of the HgX₂/PEG complexes appear to be 7-coordinate with a geometry that resembles a hexagonal bipyramid with one open site. In the EO4 complexes the fifth coordination site appears to be a very weak donor interaction from a halide of a

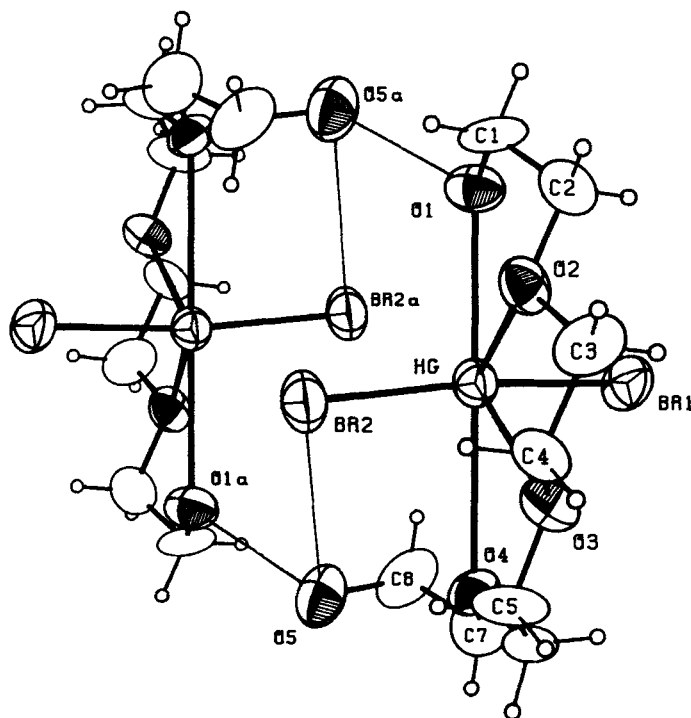

Figure 5 $[\text{HgBr}_2(\text{EO4})]$. The Hg-Br(2)^a distance is long (4.157(2)Å) but in a geometrically significant position. The dimeric unit shown resides around a crystallographic centre of inversion. The symmetry code 'a' refers to \bar{x} , 1-y, 1-z.

neighboring molecule in the hydrogen bonded dimers. The distances are long ($\text{Hg-Br}(2)^a = 4.157(2)\text{\AA}$, $\text{Hg-I}(2)^a = 4.041(1)\text{\AA}$); however, they are in geometrically significant positions. Each resides in the equatorial plane (maximum deviation = 0.25\AA for any of the five equatorial atoms in either structure) with $\text{O}(1)\text{-Hg-X}(2)^a$ angles of $75.1(2)^\circ$ (Br) and $78.5(3)^\circ$ (I). This positions an open site between the long $\text{Hg-X}(2)^a$ and longest Hg-O separations ($\text{Hg-O}(4) = 2.95(1)\text{\AA}$, Br; $3.060(9)\text{\AA}$, I). In the EO5 complexes discussed below, a fifth oxygen atom resides in the position occupied by $\text{X}(2)^a$ in these structures.

In addition to the $\text{Hg-X}(2)^a$ interactions, the EO4 complexes dimerize *via* hydrogen bonding. The contact geometries suggest that the major hydrogen bonding pattern includes a hydrogen bond from $\text{O}(1)$ to the uncoordinated $\text{O}(5)^a$ and from $\text{O}(5)$ to $\text{X}(2)$ as depicted in Figure 5. We cannot rule out the possibility of a hydrogen bond from $\text{O}(5)$ to an $\text{X}(2)$ atom in a symmetry related molecule not depicted in Figure 5. Despite the hydrogen bonding to $\text{X}(2)^a$, the Hg-X distances are equivalent.

The EO4 ligands adopt a D_{3d} -like conformation found for 18-crown-6 with the exception of the $\text{O}(4)\text{-C}(7)\text{-C}(8)\text{-O}(5)$ fragment. The C-O-C-C torsion angles are all *anti* and the O-C-C-O angles alternate $\pm g$ except that $\text{O}(4)\text{-C}(7)\text{-C}(8)\text{-O}(5)$ is g^- rather than g^+ . A g^- angle would have brought $\text{O}(5)$ into position for coordination to Hg.

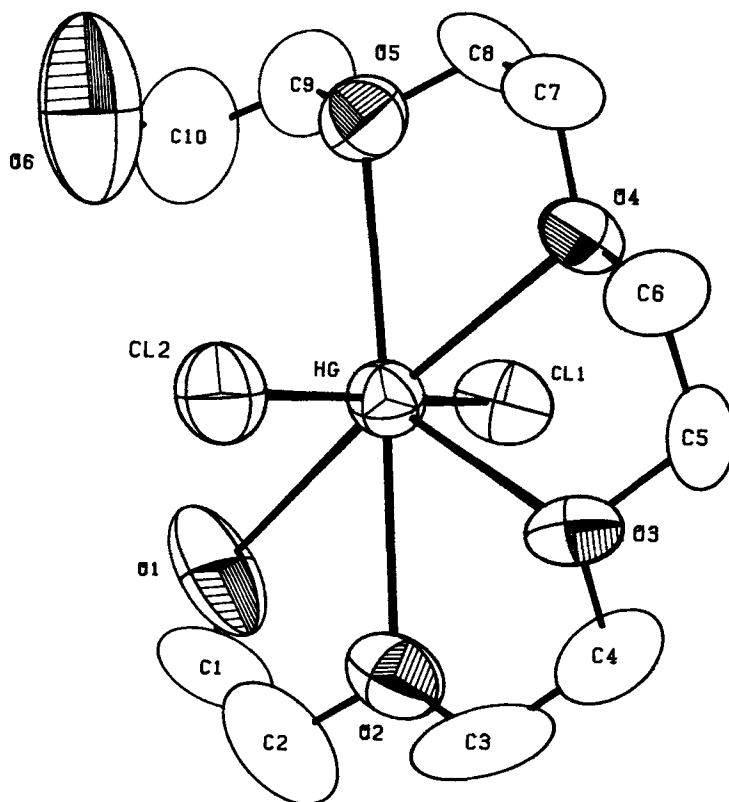

Figure 6 One orientation of $[\text{HgCl}_2(\text{EO5})]$. In the alternate orientation $\text{O}(6)$ is coordinated and $\text{O}(1)$ is dangling.

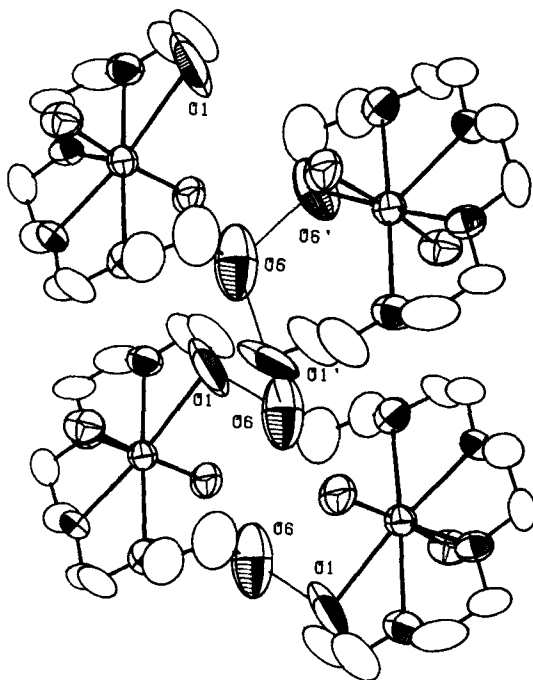

Figure 7 Four asymmetric units of $[\text{HgCl}_2(\text{EO5})]$ including two of each orientation of the terminal groups. Some of the hydrogen bonding possibilities are depicted.

$[\text{HgCl}_2(\text{EO5})]$

The structure of this complex is depicted in Figure 6. The structure is disordered such that either O(1) or O(6) can be coordinated to Hg but not both at the same time. This creates an equatorial plane of five oxygen atoms around a slightly bent Cl-Hg-Cl fragment. Again, one site in a hexagonal plane is open with the longest Hg-O separations next to the open site (either Hg-O(1), O(5) or Hg-O(2), O(6')).

The conformation of the EO5 ligand is nearly identical to the EO4 complexes discussed above. C-O-C-C torsion angles are all *anti* and the O-C-C-O torsion angles alternate $\pm g$ except for the angle involving the uncoordinated oxygen atom which is *gauche* but of the opposite sign.

The hydrogen bonding appears to be exclusively between the alcoholic oxygen atoms. Alcoholic atoms both accept and donate hydrogen bonds in the uncoordinated orientation and donate only when coordinated to Hg. The disorder and some of the resulting possible orientations for hydrogen bonding are depicted in Figure 7.

$[\text{HgBr}_2(\text{EO5})\text{HgBr}_2]_2$

This complex crystallizes as a 2/1 (Hg/EO5) complex rather than the 1/1 complexes observed for the EO4 and EO5 chloride reactions. Figure 8 illustrates the dimeric nature of the complex. Hg(1) is coordinated to an EO5 molecule and two bromides. One bromide and the coordinated alcoholic atom (O(1)) bridge Hg(1) to Hg(2). Hg(2) has an additional terminal Br interaction and is bridged to an Hg(2) position related

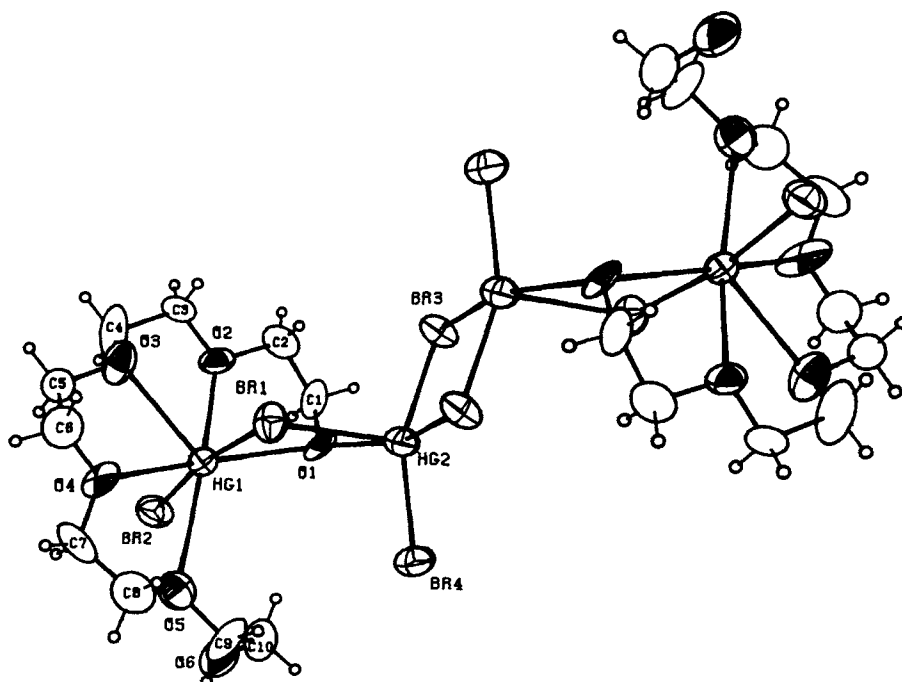

Figure 8 $[\text{HgBr}_2(\text{EO}5)\text{HgBr}_2]_2$. The dimer resides around a crystallographic centre of inversion.

by a centre of inversion producing the dimer depicted in Figure 8. The $\text{Hg}(2)\text{-Hg}(2)^a$ vector corresponds to unit cell direction c , with the long dimension of the dimer aligned in the general direction of the bc diagonal.

The 7-coordinate $\text{Hg}(1)$ has a coordination environment nearly identical to that found for $[\text{HgCl}_2(\text{EO}5)]$ and has several features in common with all of the PEG structures described in this paper which wrap Hg. The glycol ligand equatorially wraps $\text{Hg}(1)$ with one terminal alcoholic oxygen atom (O(6)) uncoordinated. This results in the pseudo-hexagonal bipyramidal geometry with one open site observed for the other PEG/Hg complexes. A bending of the axial $\text{Br}(1)\text{-Hg}(1)\text{-Br}(2)$ angle ($170.2(1)^\circ$) toward the open site is again observed. The five coordinated oxygen atoms are planar to within 0.36\AA with $\text{Hg}(1) < 0.004\text{\AA}$ out of this mean plane.

The $\text{Hg}(1)\text{-Br}(1)$ bond length ($2.459(4)\text{\AA}$) is only slightly lengthened over $\text{Hg}\text{-Br}(2)$ ($2.436(4)\text{\AA}$) despite its donor bridging interaction with $\text{Hg}(2)$. The pattern of $\text{Hg}\text{-O}$ separations is again similar to the other PEG/Hg structures. The two oxygen atoms closest to the open area have the longest $\text{Hg}(1)\text{-O}$ distances ($2.88(2)\text{\AA}$ for both the alcoholic, bridging O(1) and the etheric O(5)). O(2) and O(4) are the next furthest at $\text{Hg}(1)\text{-O} = 2.72(2)$ and $2.77(2)\text{\AA}$ and O(3) has the shortest $\text{Hg}(1)\text{-O}$ contact of $2.69(2)\text{\AA}$. The range in $\text{Hg}(1)\text{-O}$ separations is 0.19\AA .

The five-coordinate $\text{Hg}(2)$ has a severely distorted geometry: either trigonal bipyramidal with axial covalent bromide bonds (Br(3), Br(4)) or square pyramidal with Br(4) in the axial position. The $\text{Hg}(2)\text{-O}(1)$ distance of $2.70(2)\text{\AA}$ is actually 0.18\AA shorter than the $\text{Hg}(1)\text{-O}(1)$ separation of $2.88(2)\text{\AA}$. The two covalent $\text{Hg}\text{-Br}$ interactions differ by 6σ . The bridging $\text{Hg}(2)\text{-Br}(3)$ distance is the longer at $2.450(3)\text{\AA}$

with $\text{Hg}(2)\text{-Br}(4) = 2.432(3)\text{\AA}$. The $\text{Hg}(2)$ coordination environment is completed by two bridging Br donor interactions $\text{Hg}(2)\text{-Br}(1) = 2.937(4)\text{\AA}$ and $\text{Hg}(2)\text{-Br}(3)^a = 3.253(4)\text{\AA}$.

There are two unique hydrogen bonds in the asymmetric unit. O(1) donates a hydrogen bond to O(6) in a symmetry related dimer. O(6) donates intramolecularly to Br(2).

DISCUSSION

Table 10 presents comparative data for HgX_2 polyether complexes. From this data and the structures described earlier, trends in Hg(II) polyether complexation are evident. First, Hg is large enough to perturb the normal conformation of 18-membered, 6-donor, macrocyclic ethers. These crown ethers coordinate Hg in a hexagonal plane with consistent internal O-Hg-O angles of *ca* 60° ; however, to do so the O-C-C-O torsion angles must expand to an average near 75° (the normal O-C-C-O torsion angles are closer to $\pm 60^\circ$ in 18-crown-6). In addition, deviations of the individual oxygen atoms from the hexagonal planes in the 18-crown-6 structures average 0.23\AA . When compared to the more appropriately sized (for 18-crown-6) Pb^{2+} ion, the stress on the crown ether is apparent. In $[\text{Pb}(\text{NO}_3)_2(18\text{-crown-6})]$,³⁵ the O-C-C-O torsion angles relax to an average of 64° and the oxygen atom deviations from the hexagonal planes average 0.16\AA .

The stress on the macrocyclic ring can even be observed in the more rigid dibenzo-18-crown-6 derivatives. Dibenzo-18-crown-6 has less conformational flexibility than 18-crown-6 and consequently, instead of an expansion of all of the O-C-C-O torsion angles and equivalent Hg-O distances as found for 18-crown-6, Hg is displaced away from the centre of dibenzo-18-crown-6. There is only a 0.092\AA range in Hg-O distances for all five structural characterizations of Hg/18-crown-6 complexes, while a range of 0.22\AA is observed in $[\text{HgI}_2(\text{dibenzo-18-crown-6})]\cdot\text{CH}_3\text{CN}$. The Hg position is closer to O(1)-O(3) than O(4)-O(6). It is interesting to note that the ethylene O-C-C-O torsion angles on the side closest to Hg average 61° , while the two such angles on the side farthest from Hg average 79° .

The stress placed on the 18-membered macrocycles is relieved by opening the chain. EO4 and EO5 mimic a crown ether by attempting to encircle Hg; however, their acyclic nature allows them to relieve the stress created by the large Hg by increasing Hg-O separations. In the 18-crown-6 complexes a very narrow range of Hg-O distances is observed (0.074\AA maximum for $[\text{HgBr}_2(18\text{-crown-6})]$). In the PEG and glyme-like structures listed in Table 10 (except for the linear EO3 complex) there is a much wider range of Hg-O separations ($0.16\text{-}0.34\text{\AA}$). This arises from the pincer-like complexation of the PEG ligand. The PEGs attempt to form a hexagonal array around Hg with internal O-Hg-O angles approaching 60° ; however, without the constraint of being cyclic the O-C-C-O torsion angles average a more normal 64° . This produces shorter Hg-O distances in the centre of the PEG ligand with progressively longer distances towards the ends of the PEG chains. In each PEG structure one end of the chain does not coordinate the metal ion and each Hg has one open site in what would be a hexagonal array around the metal ion. This pseudo-hexagonal bipyramidal geometry with one open site and a coordination number of only 7 may be a favourable one for Hg. It has been observed in other crown-like molecules with cycles larger than 18 members.^{36,37}

Given the differences in halide, polyether coordination, and coordination number, the average Hg-O distances in all of the compounds are quite similar with only a 0.14Å range. This is a result of the crown ether complexes all having fairly equal Hg-O separations, while in the PEG structures the shortest and longest Hg-O distances are observed. Both features of these complexes are a direct result of the ligand strain discussed above. It is also interesting to note that the differences in Hg-O (alcoholic) versus Hg-O (etheric) distances are due to geometric position rather than to the basicity of the donors.

A comparison of the nearly linear X-Hg-X fragment in all compounds in Table 10 reveals very little difference in Hg-X distance for a given halide. The ranges in average Hg-X (covalent) distances are 0.063Å for X=Cl, 0.050Å for X=Br, and 0.022Å for X=I. This observation is made despite a range in coordination number from 5–7, a variable number of bridging donor halide interactions in some of the complexes, hydrogen bond acceptance by some of the halides, and a range in X-Hg-X angles of 26.6°. The PEG structures all exhibit a bending of this fragment toward the open side of the molecule.

The EO3 structure, [(HgCl₂)₃(EO3)], is the only example of a coordination type involving a linear PEG. This coordination mode is similar to that predicted by Frère *et al.*²³ for complexation of HgCl₂ with PEGs from aqueous or ethanolic solutions. Under our complexation conditions the normal mode of coordination for PEGs is a wrapping pattern which mimics crown ether coordination. Given our observed pattern for PEG complexes however, if EO3 were to coordinate in a similar fashion, only three equatorial coordination sites would be occupied. In the observed structure with a linear PEG, each Hg ion adopts a more normal pentagonal bipyramidal geometry, with no open coordination sites. The only compressed angles in the pentagonal planes are the O-Hg-O angles which (like all of the PEG structures) average near 60° (61.8(8)°).

CONCLUSIONS

Mercury can coordinate in the cavity of 18-membered, 6-donor macrocycles, but only by expansion of the O-C-C-O torsion angles. PEGs will normally mimic crown ethers in forming an equatorial girde of oxygen donors; however, the O-C-C-O torsion angles relax to *ca* 65° and this results in a pincer-like coordination of Hg. Hg-X distances are fairly invariant despite coordination number and other interactions the halide ions participate in. Given the trends observed here it would be interesting to further study these conclusions with polyethers that form 6- rather than 5-membered chelate rings, and to investigate the effects of more covalent interactions with softer donor atoms.

Acknowledgements

The diffractometer was purchased with funds provided by the U.S. National Science Foundation Chemical Instrumental Program.

Supplementary Material

Tables of fractional coordinates for hydrogen atoms, thermal parameters, bond distances and angles, least-squares planes results, hydrogen bonding contact

geometries, torsion angles, and observed and calculated structure factors (72 pages) are available from RDR upon request.

References

1. S.V. Luis, M.I. Burguete and R.V. Salvador, *J. Inclusion Phenom. Mol. Recognit. Chem.*, **10**, 341 (1991).
2. R.M. Izatt, R.L. Bruening, W. Geng, M.H. Cho and J.J. Christensen, *Anal. Chem.*, **59**, 2405 (1987).
3. J. Strzelbicki, W. Charewicz, J. Beger and L. Hinz, *Can. J. Chem.*, **66**, 1695 (1988).
4. C.R. Paige and M.F. Richardson, *Can. J. Chem.*, **62**, 332 (1984).
5. D.A. Pears, J.F. Stoddart, J. Crosby, B.L. Allwood and D.J. Williams, *Acta Cryst.*, **C42**, 51 (1986).
6. M.G.B. Drew, K.C. Lee and K.F. Mok, *Inorg. Chim. Acta*, **155**, 39 (1989).
7. Y. Kawasaki and Y. Matsuura, *Chem. Lett.*, 155 (1984).
8. M. Pietraszkiewicz, R. Gasiorowski and Z. Brzózka, *J. Inclusion Phenom. Mol. Recognit. Chem.*, **9**, 259 (1990).
9. J.S. Bradshaw, K.E. Krakowiak, R.M. Izatt, R.L. Bruening and B.J. Tarbet, *J. Heterocyclic Chem.*, **27**, 347 (1990).
10. N.W. Alcock, E.H. Curzon and P. Moore, *J. Chem. Soc., Dalton Trans.*, 2813 (1984).
11. N.G. Vanifatova, N.V. Isakova, O.M. Petrukhin and Yu.A. Zolotov, *Zh. Neorg. Khim.*, **36**, 792 (1991).
12. N.G. Vanifatova, N.V. Isakova and O.M. Petrukhin, *Zh. Neorg. Khim.*, **36**, 804 (1991).
13. M. Yokoyama, H. Ishihara, R. Iwamoto and H. Tadokoro, *Macromol.*, **2**, 184 (1969).
14. R. Iwamoto, *Bull. Chem. Soc. Jpn.*, **46**, 1114 (1973).
15. R. Iwamoto, *Bull. Chem. Soc. Jpn.*, **46**, 1118 (1973).
16. R. Iwamoto, *Bull. Chem. Soc. Jpn.*, **46**, 1123 (1973).
17. R. Iwamoto, *Bull. Chem. Soc. Jpn.*, **46**, 1127 (1973).
18. G. Weber, *Acta Cryst.*, **B36**, 2779 (1980).
19. R. Tabeta and H. Saitō, *Bull. Chem. Soc. Jpn.*, **58**, 3215 (1985).
20. G. Wulfsberg, *Inorg. Chem.*, **15**, 1791 (1976).
21. G. Wulfsberg and A. Weiss, *J. Chem. Soc., Dalton Trans.*, 1640 (1977).
22. S. Indumathy, K.R. Sridharan, J. Ramakrishna and G. Wulfsberg, *Z. Naturforsch.*, **41a**, 236 (1986).
23. Y. Frère, Y. Guilbert and P. Gramain, *New J. Chem.*, **12**, 773 (1988).
24. R.D. Rogers, A.H. Bond, S. Aguinaga and A. Reyes, *J. Am. Chem. Soc.*, **114**, 2967 (1992).
25. R.D. Rogers, A.H. Bond and S. Aguinaga, *J. Am. Chem. Soc.*, **114**, 2960 (1992).
26. R.D. Rogers, E.J. Voss and R.D. Etzenhouser, *Inorg. Chem.*, **27**, 533 (1988).
27. R.D. Rogers, R.D. Etzenhouser, J.M. Murdoch and E. Reyes, *Inorg. Chem.*, **30**, 1445 (1991).
28. R.D. Rogers, A.N. Rollins, R.F. Henry, J.S. Murdoch, R.D. Etzenhouser, S.E. Huggins and L. Nuñez, *Inorg. Chem.*, **30**, 4946 (1991).
29. R.D. Rogers, M.M. Benning, R.D. Etzenhouser and A.N. Rollins, *J. Chem. Soc., Chem. Commun.*, 1586 (1989).
30. R.D. Rogers, M.M. Benning, R.D. Etzenhouser and A.N. Rollins, *J. Coord. Chem.*, **26**, 299 (1992).
31. A. Hazell, *Acta Cryst.*, **C44**, 88 (1988).
32. G.M. Sheldrick, SHELX76, a system of computer programs for X-ray structure determination as locally modified. University of Cambridge, England (1976).
33. G.M. Sheldrick, SHELXS, *Acta Cryst.*, **A46**, 467 (1990).
34. "International Tables for X-ray Crystallography". Kynoch Press, Birmingham, England, Vol. IV, 1974, pp. 72, 99, 149 (present distributor: Kluwer Academic Publishers, Dordrecht).
35. R.D. Rogers and A.H. Bond, *Inorg. Chim. Acta*, **192**, 163 (1992).
36. K. Onan, J. Rebeck, Jr., T. Costello and L. Marshall, *J. Am. Chem. Soc.*, **105**, 6759 (1983).
37. J. Rebeck, Jr., T. Costello, L. Marshall, R. Wattlely, R.C. Gadwood and K. Onan, *J. Am. Chem. Soc.*, **107**, 7481 (1985).